

2004 - 2009 Cadillac XLR: GM TechLink: No Fob Detected Message

Source: GM TechLink

Date: February 20, 2014

A No Fob Detected message may be displayed on the Driver Information Center of some **2004 - 2009 Cadillac XLR** and 2005-2013 Corvette models when attempting to start the vehicle. The engine may not crank/start and the vehicle's doors may not open through passive entry. However, the vehicle will always start when the Remote Keyless Entry transmitter (key fob) is placed in the instrument panel compartment pocket. This condition may be caused by an internal transistor of the Remote Control Door Lock Receiver (RCDLR) module not operating properly.

To diagnose this condition, be sure the vehicle battery is adequately charged to start vehicle.

Next, remove the battery from the key fob. Using a DVOM, measure the voltage. Be sure the key fob battery voltage is between 2 to 3 volts. If not, replace the battery. Test operation of the vehicle again. If the vehicle no longer exhibits the condition, the vehicle is repaired.

If the vehicle has a known good key fob (not placed in the instrument panel compartment pocket), press the Engine Start Button and listen for a click noise or a series of click noises from the RCDLR. If there is only one click (instead of a series of clicks), the transistor internal to the RCDLR is not operating properly. For this condition, replace the RCDLR module.

The RCDLR module on the Corvette is located above the radio behind the instrument panel trim on the right side. (Fig. 12) On the XLR, the RCDLR module is located on the top right of the instrument panel under the upper

instrument panel pad. (Fig. 13)

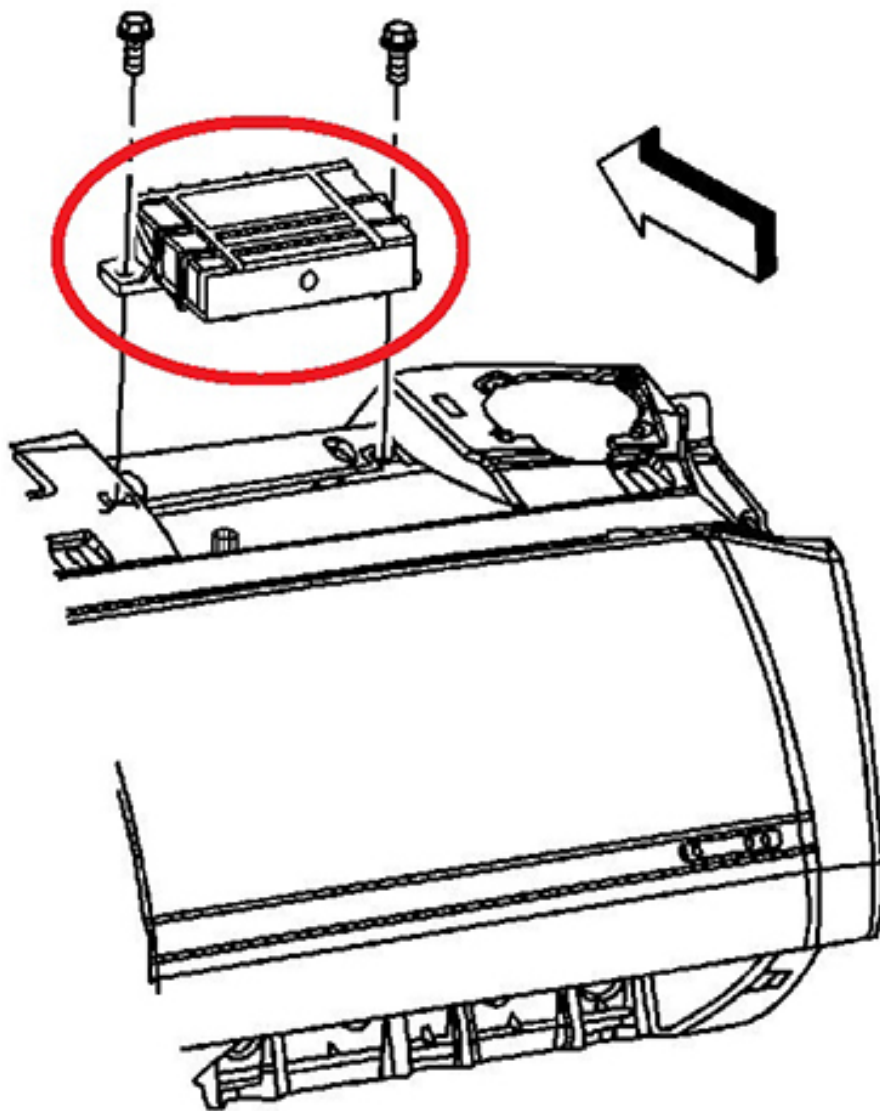

Fig. 13

Online URL:

<https://www.xlr-net.com/knowledgebase/article/2004-2009-cadillac-xlr-gm-techlink-no-fob-detected-message-81.html>